

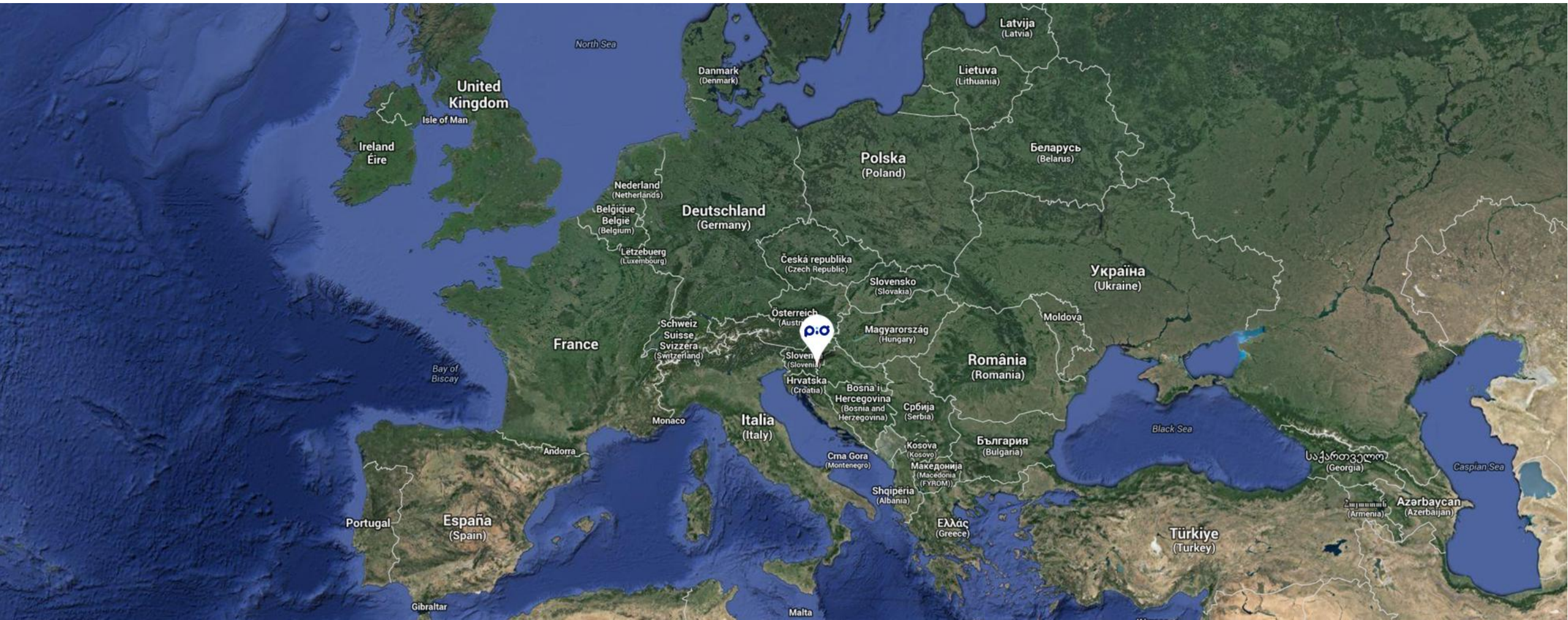

Iskra PIO  
Clean and cleaning  
technology

Trubarjeva cesta 5, 8310 Šentjernej, Slovenia



Iskra PIO Ltd is a privately owned company with registered office and production facilities in Slovenia. Since we were established in 1991, we have developed into an innovative engineering and manufacturing company with more than 1000 customers worldwide.

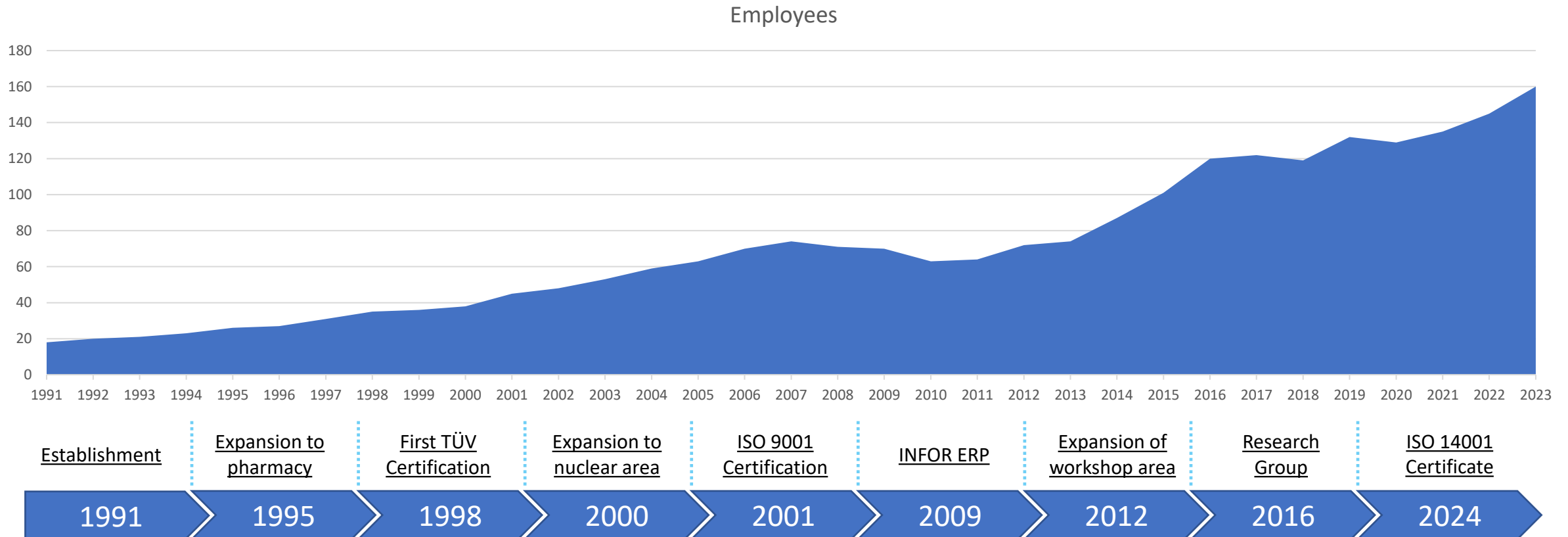

The company's main activity is design, manufacturing, integration, automation and validation of pharmaceutical equipment.

Iskra PIO today:

- No. of employees: approx. 160
- Company area: 4.426 m<sup>2</sup>
- Share capital: 1.132.627,00 €
- Turnover: 15-20 Mio €
- Export: 50 %
- Certificates:
  - DIN EN ISO 9001:2015 - QMS
  - DIN EN ISO 14001:2015 - EMS
  - SIST EN 1127-1:2008 - ATEX
  - SIST EN 1090-2:2008 + A1:2012 - Welding

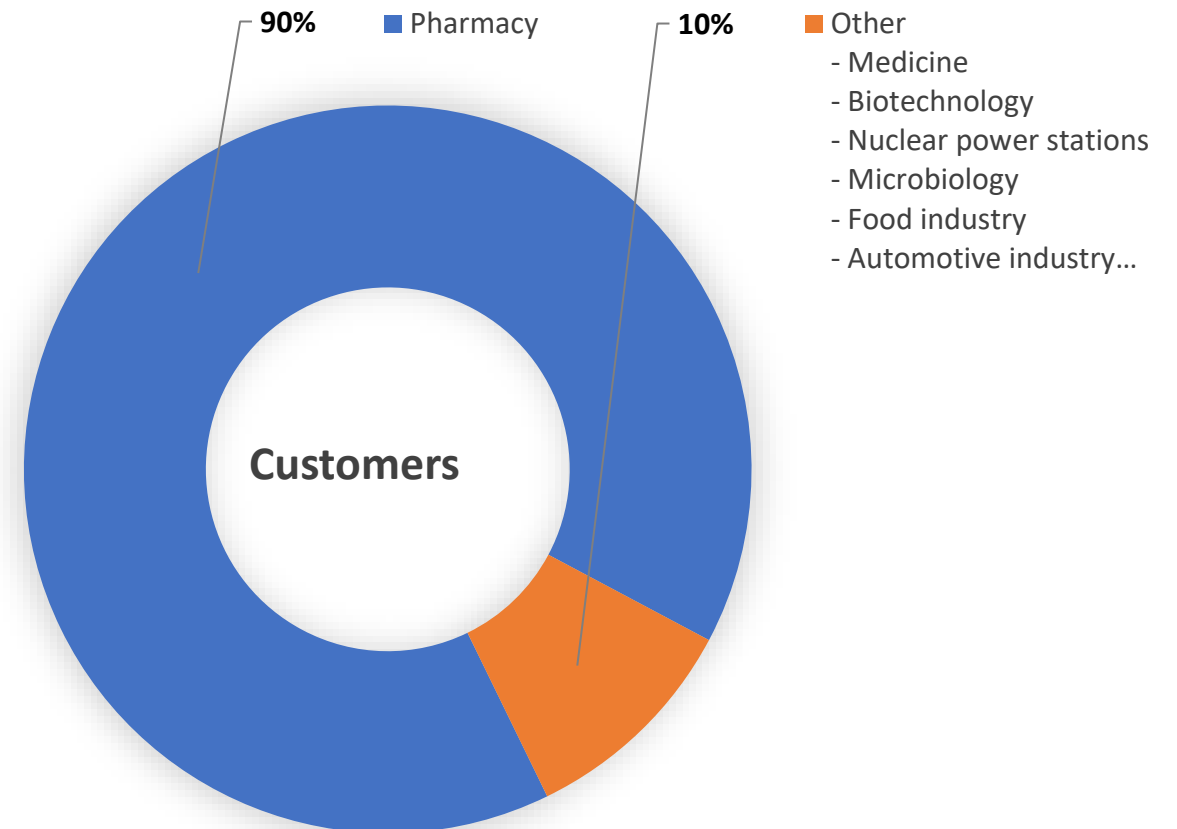

# References



To be a preferred partner in the supply of more demanding manufacturing and processing equipment for the pharmaceutical industry.

We are customer-oriented company with many advantages:

- Flexibility** All our equipment is designed according to customer's needs
- Innovation** We believe that continuous investments in R&D are right way to success
- Experience** In more than 30 years we have learned how to assure best quality and user-friendly design
- Reliability** We produce professional equipment and provide 24/7 support to our customers

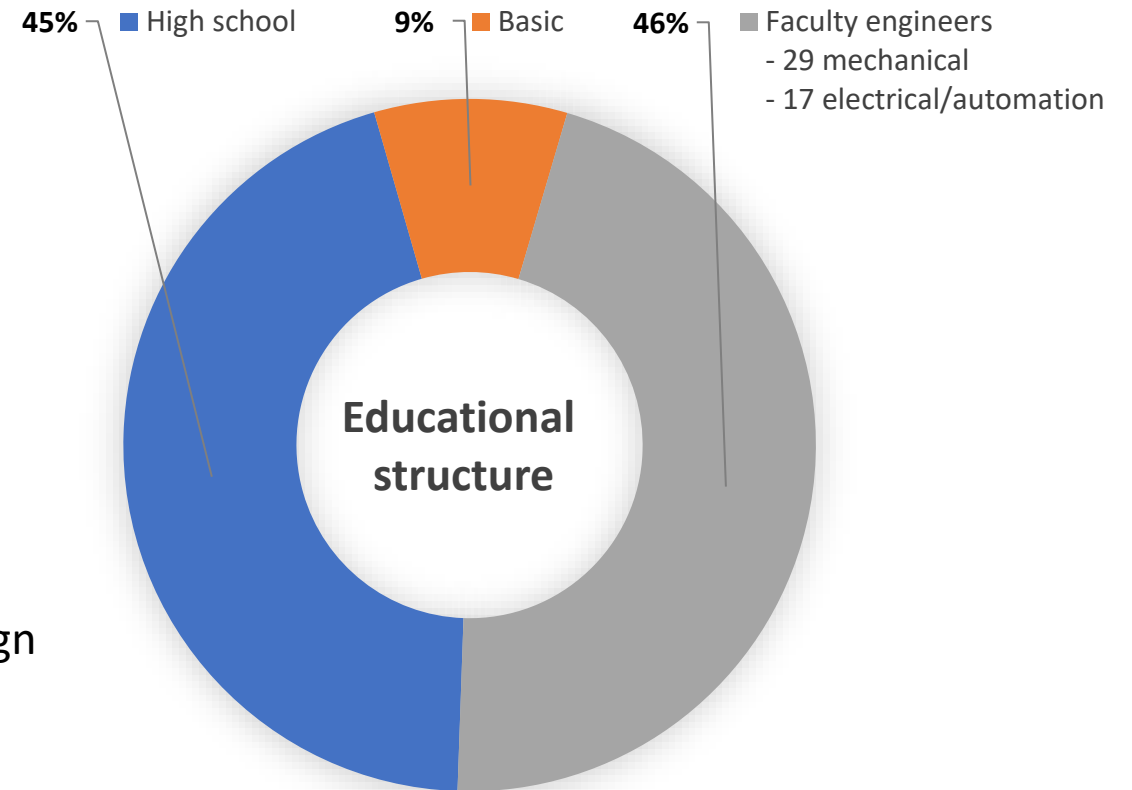

# Clean rooms

Various types for different applications:

- Modular clean rooms
- Regular clean rooms
- SmartCon GMP Clean rooms

Controls:

- operation and safety functions
- regulation of temperature and humidity
- working/standby regime

Use:

- Food industry, Electronic, Pharmacy, Biology, Microbiology, Nuclear medicine, Oncology,...

Directives:

- euGMP, ISO 14644-1: 2015

Customization:

- Designed according to customer demands and needs.



# Personal air locks

Various types for different applications:

- Air-showers
- Mist-showers

Controls:

- operation and safety functions

Use:

- Food industry, Electronic, Pharmacy, Biology, Microbiology, Nuclear medicine, Oncology,...

Directives:

- euGMP, ISO 14644-1: 2015

Customization:

- Designed according to customer demands and needs.



# Material air locks

Various types for different applications:

- Passive pass-box chambers
- Active pass-box chambers
- H2O2 Pass-box chambers
- De-dusting cabin

Controls:

- operation and safety functions

Use:

- Food industry, Electronic, Pharmacy, Biology, Microbiology, Nuclear medicine, Oncology,...

Directives:

- euGMP, ISO 14644-1: 2015

Customization:

- Designed according to customer demands and needs.

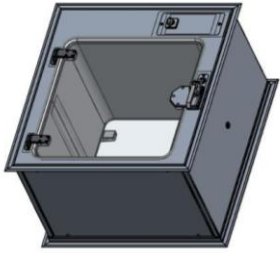

# Safety cabinets

Various types for different applications.

## Ventilation:

- HEPA filtration
- Laminar air flow 0,45 m/s

## Controls:

- operation and safety functions

## Protection:

- operator, environment, product

## Use:

- Electronic, Pharmacy, Biology, Micro-biology, Nuclear medicine, Oncology,...

## Directives:

- SIST EN 12469: 2000, DIN 12980: 2017, NSF: 2008, euGMP, ISO 14644-1: 2015

## Customization:

- Designed according to customer demands and needs.



# Isolators

Various types for different applications:

- Containment isolators
- Isolators for sterile applications
- Flexible isolators
- Nuclear medicine hot cell

Controls:

- operation and safety functions

Use:

- Pharmacy, Biology, Micro-biology, Nuclear medicine, Oncology,...

Customization:

- Designed according to customer demands and needs.

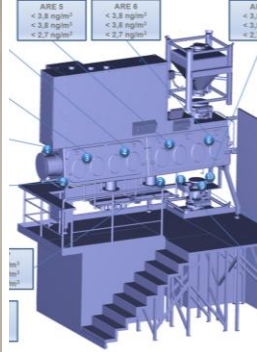

# LAF cabins

Various types for different applications:

- LAF/UDF units
- Sampling booths
- Weighing booths

Controls:

- operation and safety functions

Use:

- Food industry, Electronic, Pharmacy, Biology, Microbiology, Nuclear medicine, Oncology,...

Customization:

- Designed according to customer demands and needs.

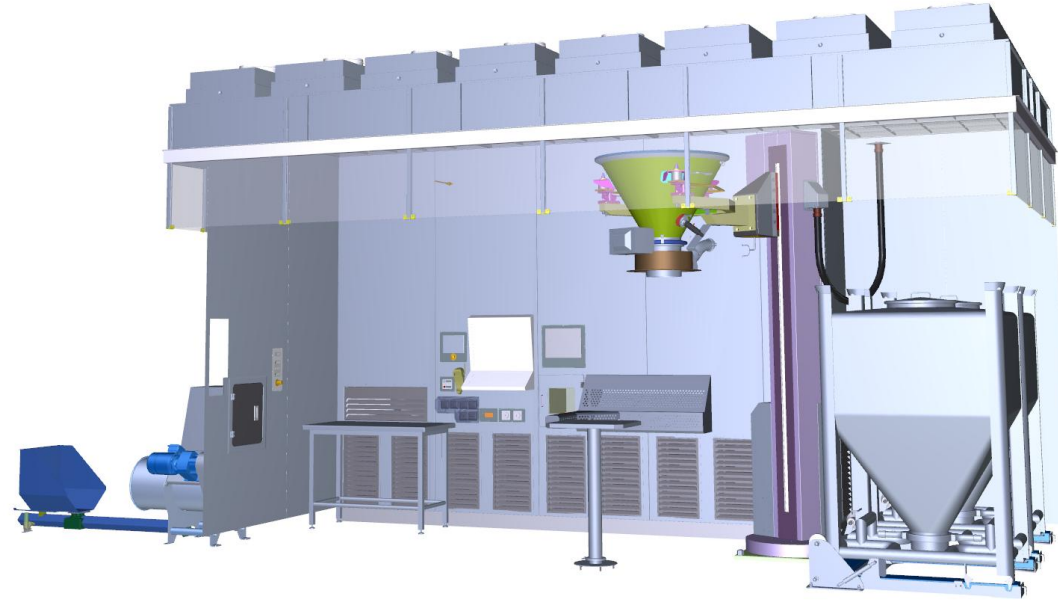

# Material handling system

Various types for different applications:

- lifting devices
- blenders
- docking stations
- milling-sieving systems
- transport systems

Controls:

- operation and safety functions

Use:

- Food industry, Electronic, Pharmacy, Biology, Microbiology, Nuclear medicine, Oncology,...

Customization:

- Designed according to customer demands and needs.



# Drying chamber

- Tray dryers:
  - ATEX execution 2G3D
  - air humidity: 1 - 100 g/kg
  - temperature: 20 - 80 °C
- drying chamber for washed equipment
- washing and drying trolleys



# Ultrasonic devices

Various types for different applications:

- Desktop ultrasonic devices
- Freestanding ultrasonic devices
- Automated ultrasonic devices

Controls:

- operation and safety functions

Use:

- Different industries like Food, Electronic, Pharmacy, Biology, Micro-biology, Hospitals, Nuclear power plants

Customization:

- Designed according to customer demands and needs.

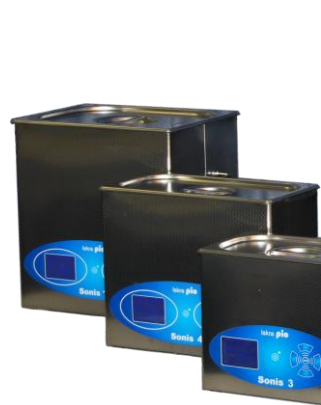

# Mobile decontamination generators

Various types for different applications:

- PIO Flash® distribution system
- H2O2 Bio-decontamination
- highly effective infection and contamination prevention - Effective against viruses, bacteria, fungi and spores
- up to 500 m3 with one device, more devices for larger area
- for decontamination wherever it is necessary to ensure microbiological cleanliness

Controls:

- operation and safety functions

Use:

- Food industry, Electronic, Pharmacy, Biology, Micro-biology, Nuclear medicine, Oncology,...

Customization:

- Designed according to customer demands and needs.



# Special equipment

## Military program

- special containers
  - Mobile Radiological Laboratory



# Special equipment

## Nuclear power plants

- radioactive waste sorting device
- under pressure chamber

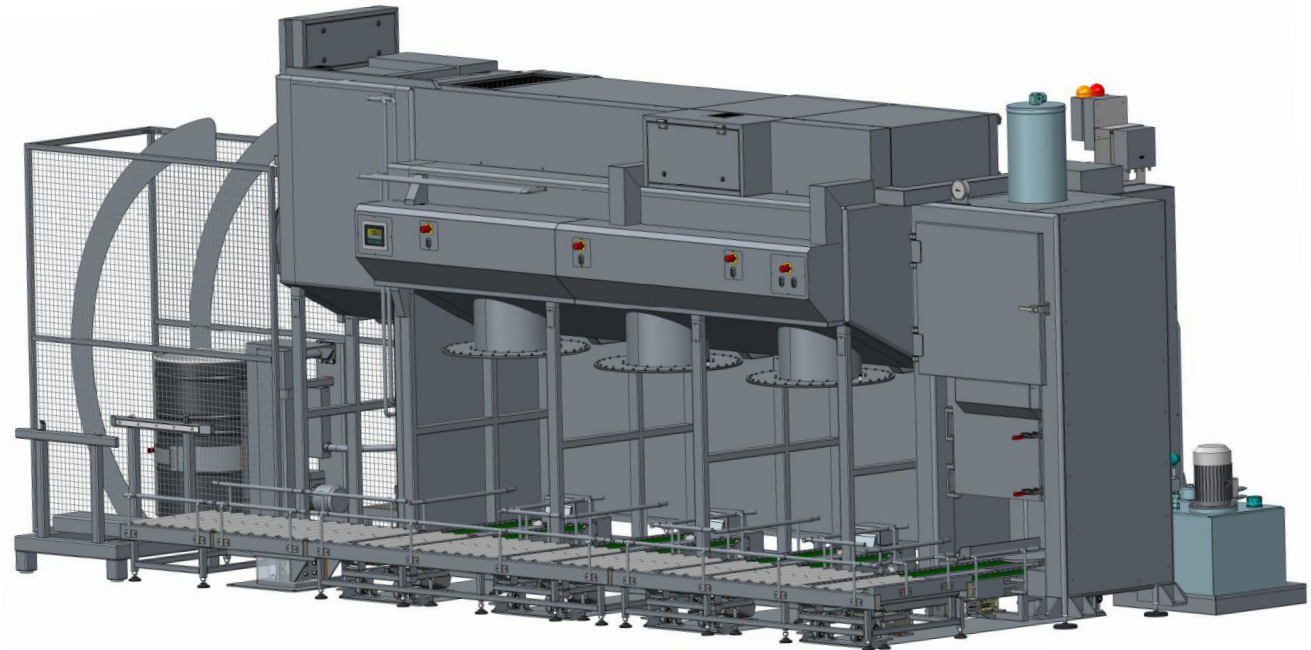
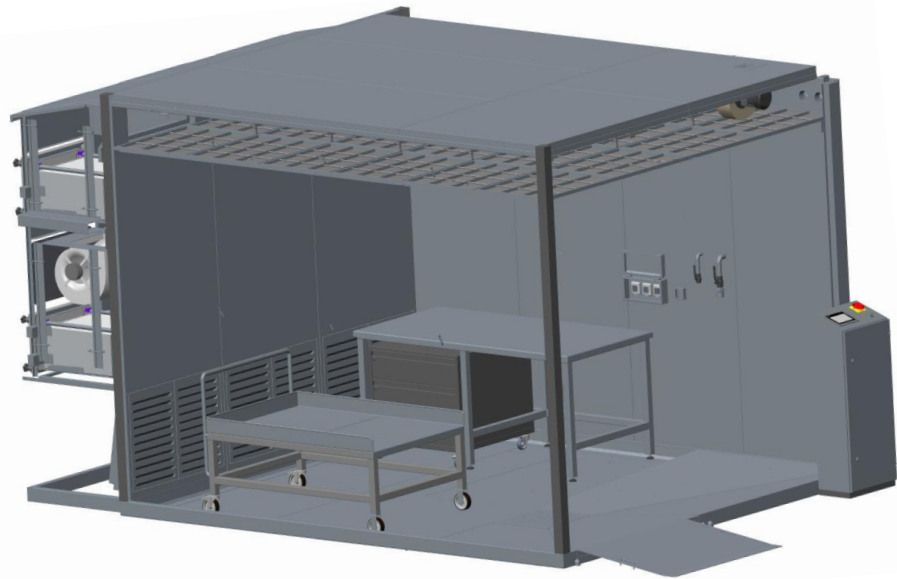
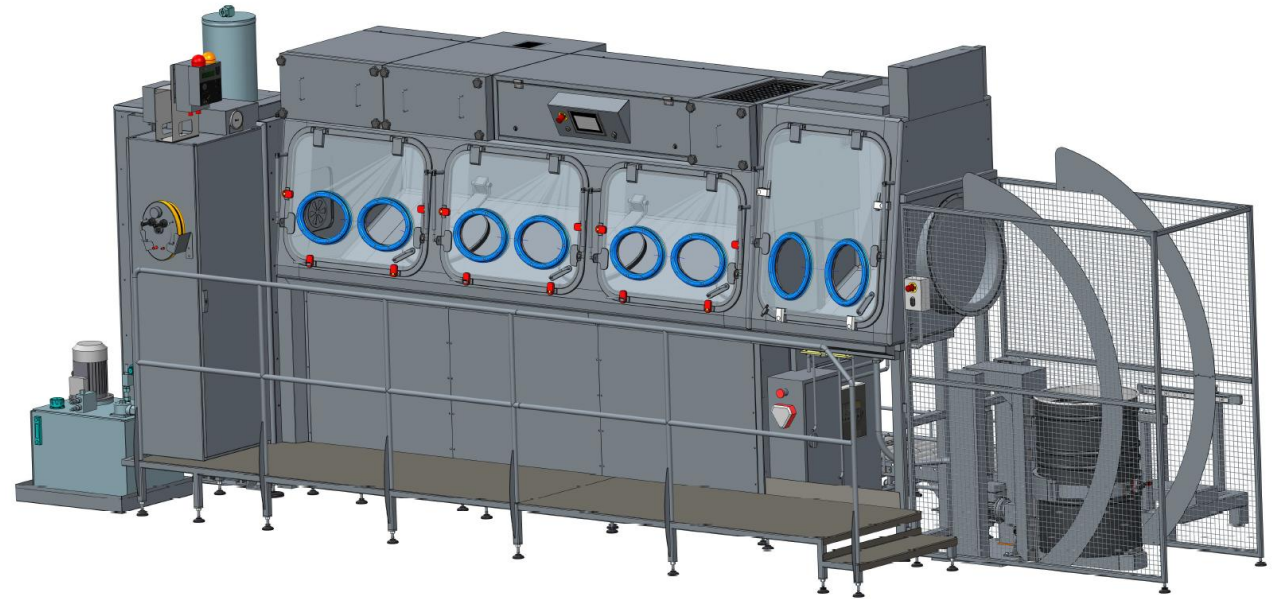

# Validation

Validation measurements in clean room areas and of equipment for clean and safe working conditions.

- particle counting, room classification
- airflow volumes, air change rates
- airflow velocity measurements
- filter in place integrity test
- KI-DISCUS test
- OEL level test
- temperature test
- relative humidity test
- room pressurization test
- visual smoke test
- recovery time test
- light level test
- noise level test





Iskra PIO d.o.o.

Trubarjeva cesta 5  
8310 Šentjernej  
Slovenia

T: +386 7 39 31 400

E: [info@iskra-pio.si](mailto:info@iskra-pio.si)

W: [www.iskra-pio.si](http://www.iskra-pio.si)

